

IMPORTANT - DO NOT DISCARD.



Magnum Heat Torch

Instructions for Use and Safety Measures

Flint Trading, Inc. or Seller is not liable for any injury, loss, damage, direct or consequential, arising out of the use or the inability to use the product or for environmental claims. It being understood that the seller/manufacturer has no means of controlling the products final use; therefore, it shall be Buyers responsibility to determine suitability of product for intended use and Buyer assumes all risks and liabilities whatsoever, in connection therewith.

Manufactured by:
Flint Trading, Inc.
115 Todd Court
Thomasville, NC 27360
Phone: (336) 475-6600
Fax: (336) 475-7900
www.flintrading.com

HOTAPE™ BY FLINT

Magnum Heat Torch

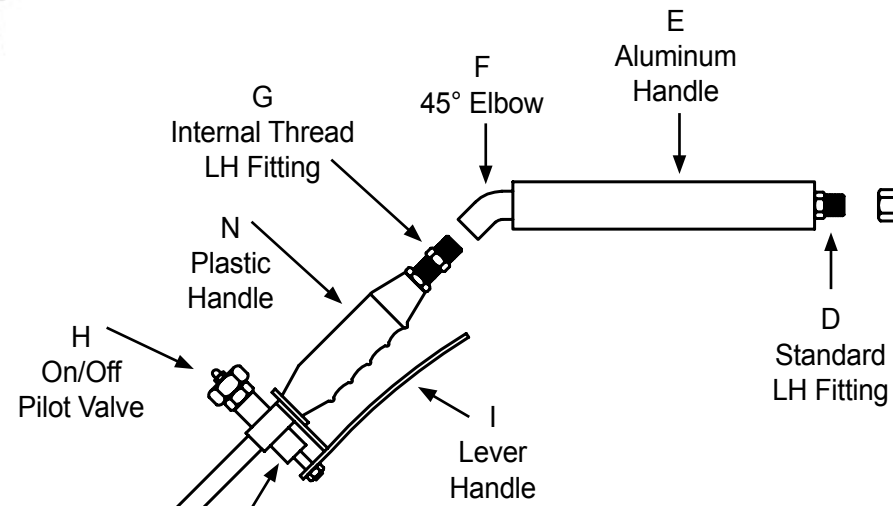
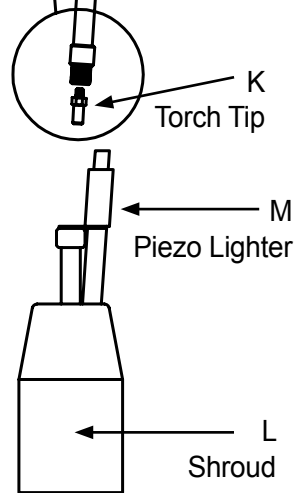
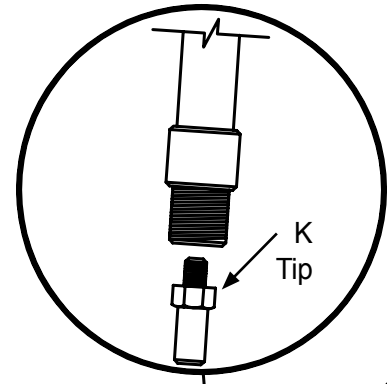

**Always use both handles
to properly direct flame
toward pavement.**

Item	Description	Part #
A	40 lb. tank	195086
B	Regulator	187923
C	30' Torch Hose	187929
D	Std. LH Fitting	187725
E	Aluminum Handle	187922
F	45° Elbow	187928
G	Internal Thread LH Fitting	187562
H	On/Off Pilot Valve	187930
I	Lever Handle	187934
J	Flame Regulator Assy.	187931
K	Torch Tip	187924
L	Single Fire Shroud w/ Piezo Lighter	187932
M	Piezo Lighter	198925
N	Plastic Handle	187925

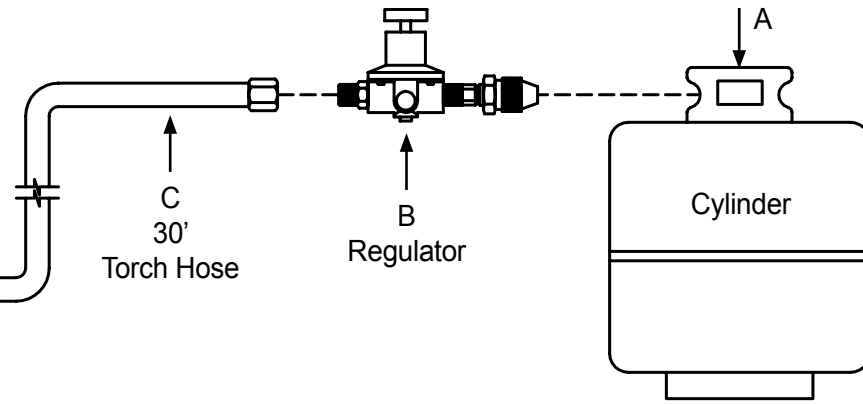

ASSEMBLY

1. Remove plastic cap from regulator inlet nut [A] and attach to cylinder valve opening [B]. Securely tighten with wrench [counterclockwise], but do not force.
2. Wrench tighten brass fitting of the rubber hose [C] to the regulator connection, then wrench tighten the other hose fitting to the torch two-hand grip handle connection [F,D].
3. Screw torch tip [E] into torch. Screw shroud [G] onto torch.
4. Close all valves before operating equipment.

OPERATION

1. Make sure valves are closed on torch.
2. Turn regulator pressure adjusting knob [A] counterclockwise until it turns without tension. [This stops inlet gas flow in high pressure chamber of regulator.]
3. Stand to side of cylinder with cylinder valve outlet facing right or left from operator. Slowly open propane cylinder valve to center open position.
4. Turn regulator pressure adjusting knob [A] five to seven turns counterclockwise.
5. Check all fittings for leak bubbles with a liquid soap solution.
6. To light torch, open on/off pilot valve [K] slightly, a 1/4 turn or less. Be certain that torch shroud [G] and tip [E] are facing away from operator. If using a standard ignition torch, use flint or spark lighter to light tip; if torch is equipped with electronic start, depress electronic start button [H]. After lighting, adjust pilot valve to desired condition.
7. Depress lever handle [J] for full torching flame and adjust regulator pressure to desired flame. [Caution: A propane flame is hard to see in outdoor lighting; use extreme care]. You may adjust the regulator pressure according to weather and pavement condition and to conserve fuel.
8. Before storing, close cylinder valve and depress lever handle to drain gas from regulator, hose and torch. Close all valves and disconnect regulator from cylinder valve.
9. Keep equipment clean and hose kink free.
10. Torch assembly must be used with a D.O.T. approved container equipped with a U.L. listed shut off valve.

EQUIPMENT PRECAUTIONS

- Keep both hands on torch handles when operating.
- Wear proper clothing, long-sleeve shirt, long pants, heavy rubber-sole shoes and gloves.
- Follow all OSHA and NFPA regulations when operating torch.
- Be sure that all torching equipment is in good working order and the cylinder valves are clean.
- Check all parts for leaks and hose wear. Repair or replace immediately.
- Stop the use of the torch if propane odor is detected. Check for leaks.
- Treat the torch as if it is always burning. At times it may be difficult to see the flame.
- Have an ABC or Halon fire extinguisher available at all times.
- Use a torch stand to direct pilot flame upward when not in use.
- Use an adjustable pilot with a complete shutoff valve.
- Only use hose listed for LP gas.
- Use no more than 50' of hose at one time.
- Use an adjustable regulator and keep it unobstructed at all times.
- Make sure flow of gas through regulator is in the proper direction. Directional flow is stamped on the regulator.
- Propane tanks should be secured in an upright position and placed at least 10' from the open flame.
- Have a spare filled LP gas tank available at all times.
- When shutting off torch, close the propane cylinder valve first allowing the remaining gas to burn out of the hose before closing the torch valve.

EQUIPMENT WARNINGS

- Do not use equipment without an operating pressure gauge.
- Do not operate any pressure gauge beyond the top of its scale or in excessive heat (above 150°F).
- Do not turn vapor cylinder on its side to increase pressure. Liquid can escape.
- Do not heat cylinder to increase pressure.
- Do not attempt to put a cylinder fire out if it cannot be done without tipping the cylinder. Let it burn.
- Do not lift a cylinder by the valve as it is made of soft brass and can be easily damaged.
- Do not leave lighted torch unattended.
- Do not play with the torch. Flame is difficult to see.
- Do not use matches to light torch.



HotTape™ Preformed Thermoplastic Pavement Markings are available in all forms and colors for lines, legends, symbols, arrows, and for restoring worn or missing thermoplastic markings. Call Flint Trading at (336) 475-6600 for more information.